



Doosan Infracore
Forklifts

TECHNICAL SPECIFICATIONS

Pneumatic Forklift Trucks

D50S / D60S / D70S-5 & D80S / D90S-5

G50S / G60S / G70S-5

5,000kg to 9,000kg Capacity

PRO5
SERIES



5,000/6,000/7,000/8,000/9,000kg Capacities

Engine Powered Forklift Trucks
Pneumatic Tire

MAIN VEHICLE SPECIFICATIONS

CHARACTERISTICS	1	Manufacture		DOOSAN	DOOSAN	DOOSAN	DOOSAN	DOOSAN	
	2	Model		D50S-5	D60S-5	D70S-5	D80S-5	D90S-5	
	3	Load Capacity	at rated load center	kg	5,000	6,000	7,000	8,000	9,000
	4	Load Center		mm	600	600	600	600	600
	5	Power type	Elec, Diesel, LPG, Gasoline		Diesel	Diesel	Diesel	Diesel	Diesel
	6	Operator type			Driver-seated	Driver-seated	Driver-seated	Driver-seated	Driver-seated
	7	Tire type	P:Pnu, E:Solid Soft, C: Cush		P	P	P	p	p
	8	Wheels (x=Driven)	Front / Rear		x 4 / 2	x 4 / 2	x 4 / 2	x 4 / 2	x 4 / 2
DIMENSIONS	9	Max. Fork Height	with STD 2-stage mast	mm	3,000	3,000	3,000	3100	3100
	10	Free Lift		mm	205	205	205	215	215
	12	Fork Carriage	ISO Class		IV	IV	IV	V	V
	13	Forks	Length x Width x Thickness	mm	1,200x150x60	1,200x180x60	1,200x180x60	1200x180x70	1200x180x70
			Fork Spacing(Min x Max)	mm	350x2,032	410x2,032	410x2,032	410x2092	410x2092
	14	Tilt of Mast	Forward / Backward	deg	15 / 10	15 / 10	15 / 10	15 / 10	15 / 10
	15	Overall Dimensions	Length to Fork Face	mm	3,507	3,568	3,647	3,970	4,040
			Overall Width	mm	2,108	2,108	2,108	2,230	2,230
			Mast Lowered Height	mm	2,500	2,500	2,500	2,835	2,835
			Mast Extended Height	mm	4,340	4,340	4,340	4,375	4,375
			Overhead Guard Height	mm	2,455	2,455	2,455	2,648	2,648
19	Overhead Guard Height	mm	2,455	2,455	2,455	2,648	2,648		
20	Seat Height	mm	1,333	1,333	1,333	1,526	1,526		
21	Turning Radius	Minimum outside	mm	3,301	3,331	3,380	3,610	3,680	
22	Load Moment Center		mm	632	632	632	725	725	
23	Aisle 90 degree stacking(add load length & clearance)		mm	3,924	3,958	4,000	4,330	4,355	
PERFORMANCE	24	Travel Speed	Loaded / Unloaded	km/h	30.0 / 33.0	29.5 / 32.5	29.0 / 32.0	29.8 / 3 3.8	27.7 / 33.4
	25	Lifting Speed	Loaded / Unloaded	mm/s	500 / 530	490 / 530	445 / 470	430 / 470	430 / 470
	26	Lowering Speed	Loaded / Unloaded	mm/s	501 / 450	501 / 450	499 / 450	500 / 450	500 / 4 50
	28	Max. drawbar pull	Loaded at 1.0 mph (1.6km / h)	kg	5,668	5,624	5,592	5,498	5,449
	30	Max. gradeability	Loaded at 1.0 mph (1.7km / h)	%	47.5	40.5	35.5	30.6	28.6
WEIGHT	32	Total Service Weight, Unloaded		kg	8,570	9,240	9,970	11,545	12,195
	33	Axle Load	Loaded, Front / Rear	kg	12,175 / 1,395	13,585 / 1,655	14,980 / 1,990	14,920 / 4,360	16,920 / 4,705
			Unloaded, Front / Rear	kg	4,435 / 4,135	4,300 / 4,940	4,150 / 5,820	4,600 / 6,500	4,680 / 7,315
	34								
CHASSIS	35	Tires	Number of wheels(F / R)		4 / 2	4 / 2	4 / 2	4 / 2	
			Size, Front		8.25x15-14PR	8.25x15-14PR	8.25x15-14PR	9.00x20-14PR	9.00x20-14PR
	36		Size, Rear		8.25x15-14PR	8.25x15-14PR	8.25x15-14PR	9.00x20-14PR	9.00x20-14PR
	37								
	38	Wheel Base	Distance	mm	2,250	2,250	2,250	2500	2,500
	39	Tread Width	Front / Rear	mm	1,584 / 1,550	1,584 / 1,550	1,584 / 1,550	1,646 / 1,750	1,646 / 1,750
40	Ground Clearance	Loaded at the lowest point	mm	176	176	176	258	258	
		Loaded at center of wheelbase	mm	205	205	205	292	292	
41	Brakes	Service		Foot / Hyd	Foot / Hyd	Foot / Hyd	Foot/Hyd	Foot/Hyd	
		Parking		Hand / Mech	Hand / Mech	Hand / Mech	Hand/Mech	Hand/Mech	
42									
43									
POWER TRAIN	44	Battery	Voltage / Ampere	V/AH	24 / 75	24 / 75	24 / 75	24 / 75	24 / 75
	49	Engine	Model		DB58S	DB58S	DB58S	DB58S	DB58S
			Rated Power(DIN)	HP/rpm	98.6 / 2200	98.6 / 2200	98.6 / 2200	98.6 / 2200	98.6 / 2200
				kW/rpm	73.6 / 2200	73.6 / 2200	73.6 / 2200	73.6 / 2200	73.6 / 2200
			Maximum Torque	N-m/rpm	363 / 1,400	363 / 1,400	363 / 1,400	363 / 1,400	363 / 1,400
	40	Cylinders / Displacements	CC	6 / 5,785	6 / 5,785	6 / 5,785	6 / 5,785	6 / 5,785	
	50	Transmission	Type		FULL AUTO	FULL AUTO	FULL AUTO	FULL AUTO	FULL AUTO
Number of Speed (Fwd / Rev)				3 / 3	3 / 3	3 / 3	3 / 3	3 / 3	
51	Hydraulic Pressure	System	bar	210	210	210	219	235	
		Attachment	bar	140	140	140	140	140	

Note: Specification values quoted in this specification sheet has been rounded. Performance may vary due to operation conditions.
Products and specifications are subject to improvement and change without prior notices.

5,000/6,000/7,000kg Capacities

Engine Powered Forklift Trucks
Pneumatic Tire

DOOSAN	DOOSAN	DOOSAN	DOOSAN	DOOSAN	DOOSAN
D50S-5	D60S-5	D70S-5	G50S-5	G60S-5	G70S-5
5,000	6,000	7,000	5,000	6,000	7,000
600	600	600	600	600	600
Diesel	Diesel	Diesel	LPG	LPG	LPG
Driver-seated	Driver-seated	Driver-seated	Driver-seated	Driver-seated	Driver-seated
P	P	P	p	p	p
x 4 / 2	x 4 / 2	x 4 / 2	x 4 / 2	x 4 / 2	x 4 / 2
3,000	3,000	3,000	3,000	3,000	3,000
205	205	205	205	205	205
IV	IV	IV	IV	IV	IV
1,200x150x60	1,200x180x60	1,200x180x60	1,200x150x60	1,200x180x60	1,200x180x60
350x2,032	410x2,032	410x2,032	350x2,032	410x2,032	410x2,032
15 / 10	15 / 10	15 / 10	15 / 10	15 / 10	15 / 10
3,507	3,568	3,647	3,507	3,568	3,647
2,108	2,108	2,108	2,108	2,108	2,108
2,500	2,500	2,500	2,500	2,500	2,500
4,340	4,340	4,340	4,340	4,340	4,340
2,455	2,455	2,455	2,455	2,455	2,455
1,333	1,333	1,333	1,333	1,333	1,333
3,301	3,331	3,380	3,301	3,331	3,380
632	632	632	632	632	632
3,924	3,958	4,000	3,924	3,958	4,000
25 / 26.5	24.5 / 26.5	24.0 / 26.5	24.0 / 25.4	23.8 / 25.4	23.6 / 25.4
415 / 445	415 / 445	415 / 445	380 / 410	380 / 410	380 / 410
490 / 460	490 / 460	490 / 460	490 / 460	490 / 460	490 / 460
4,908	4,875	4,875	5,010	4,990	4,965
39.4	34.1	30.3	40.9	35.5	31.3
8,395	9,085	9,810	8,235	8,905	9,635
12,010 / 1,385	13,430 / 1,655	14,820 / 1,990	11,840 / 1,395	13,260 / 1,645	14,650 / 1,985
4,270 / 4,125	4,145 / 4,940	3,985 / 5,830	4,100 / 4,135	3,975 / 4,930	3,815 / 5,820
4 / 2	4 / 2	4 / 2	4 / 2	4 / 2	4 / 2
8.25x15-14PR	8.25x15-14PR	8.25x15-14PR	8.25x15-14PR	8.25x15-14PR	8.25x15-14PR
8.25x15-14PR	8.25x15-14PR	8.25x15-14PR	8.25x15-14PR	8.25x15-14PR	8.25x15-14PR
2,250	2,250	2,250	2,250	2,250	2,250
1,584 / 1,550	1,584 / 1,550	1,584 / 1,550	1,584 / 1,550	1,584 / 1,550	1,584 / 1,550
176	176	176	176	176	176
205	205	205	205	205	205
Foot / Hyd	Foot / Hyd	Foot / Hyd	Foot / Hyd	Foot / Hyd	Foot / Hyd
Hand / Mech	Hand / Mech	Hand / Mech	Hand / Mech	Hand / Mech	Hand / Mech
24 / 75	24 / 75	24 / 75	12 / 75	12 / 75	12 / 75
RKINS/1104D-44T	RKINS/1104D-44T	RKINS/1104D-44T	G643(E)	G643(E)	G643(E)
92.7 / 2,400	92.7 / 2,400	92.7 / 2,400	93 / 2,450	93 / 2,450	93 / 2,450
69.1 / 2,400	69.1 / 2,400	69.1 / 2,400	69 / 2,450	69 / 2,450	69 / 2,450
323/ 1,600	323/ 1,600	323/ 1,600	31 / 1,400	31 / 1,400	31 / 1,400
6 / 4,400	6 / 4,400	6 / 4,400	6 / 4,294	6 / 4,294	6 / 4,294
Autoshift	Autoshift	Autoshift	Power Shift	Power Shift	Power Shift
2 / 2	2 / 2	2 / 2	2 / 2	2 / 2	2 / 2
210	210	210	210	210	210
140	140	140	140	140	140

DIMENSIONAL DRAWING

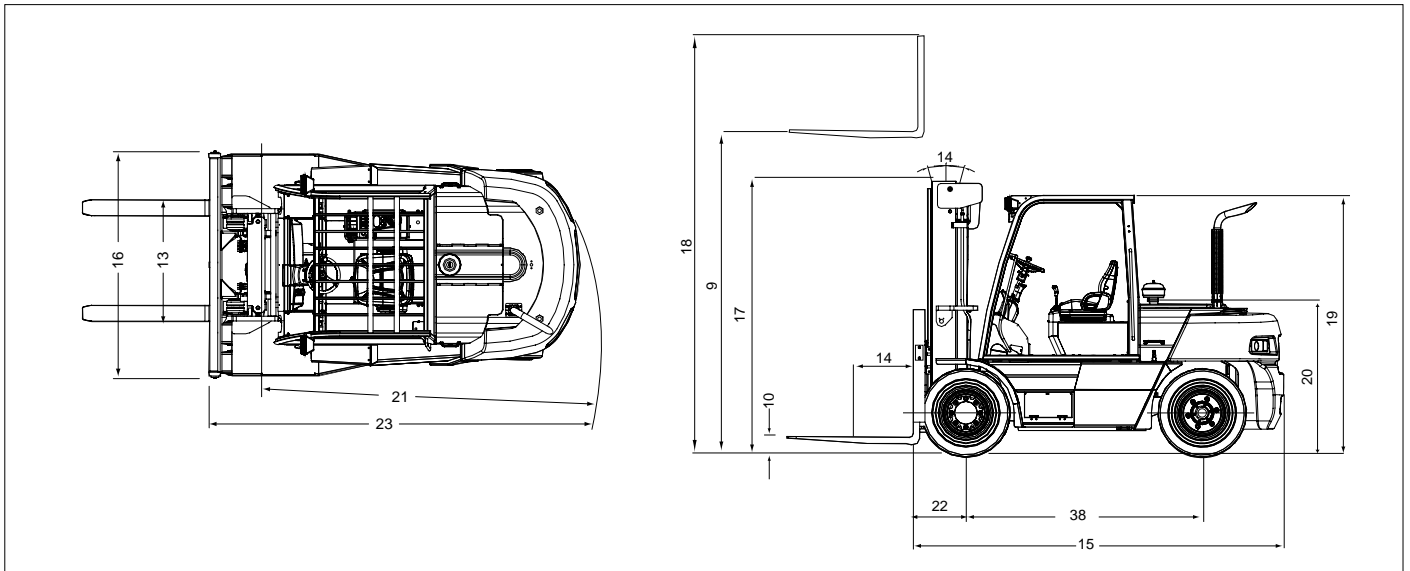

MAST SPECIFICATIONS and RATED CAPACITIES

D/G50S-5

Mast type	Maximum Fork Height	Fully Lowered Height	Fully Extended Height	Free Lift	Rated Load Capacities		
			With Load Backrest	With Load Backrest	D/G50S-5		
					Tilt Angle		Load Capacities
					Double Pneumatic		Double Pneumatic
					FWD	BWD	LC 600mm
STD	mm	mm	mm	mm	deg	deg	kg
	3,000	2,495	4,275	205	15	10	5,000
	3,500	2,745	4,775	205	15	10	5,000
	3,700	2,845	4,975	205	15	10	5,000
	4,000	2,995	5,275	205	15	10	5,000
	4,500	3,345	5,775	205	15	10	5,000
	5,000	3,595	6,275	205	15	10	5,000
5,500	3,845	6,775	205	15	10	4,900	
6,000	4,095	7,275	205	15	10	4,725	
FFT	4,550	2,540	5,570	1,580	15	10	4,900
	5,000	2,690	6,020	1,730	15	10	4,750
	5,600	2,890	6,620	1,930	15	10	4,550
	6,050	3,040	7,070	2,080	15	10	4,400

D/G60S-5

Mast type	Maximum Fork Height	Fully Lowered Height	Fully Extended Height	Free Lift	Rated Load Capacities		
			With Load Backrest	With Load Backrest	D/G60S-5		
					Tilt Angle		Load Capacities
					Double Pneumatic		Double Pneumatic
					FWD	BWD	LC 600mm
STD	mm	mm	mm	mm	deg	deg	kg
	3,000	2,495	4,275	205	15	10	6,000
	3,500	2,745	4,775	205	15	10	6,000
	3,700	2,845	4,975	205	15	10	6,000
	4,000	2,995	5,275	205	15	10	6,000
	4,500	3,345	5,775	205	15	10	6,000
	5,000	3,595	6,275	205	15	10	6,000
5,500	3,845	6,775	205	15	10	5,875	
6,000	4,095	7,275	205	15	10	5,675	
FFT	4,550	2,540	5,570	1,580	15	10	5,900
	5,000	2,690	6,020	1,730	15	10	5,725
	5,600	2,890	6,620	1,930	15	10	5,500
	6,050	3,040	7,070	2,080	15	10	5,300

D/G70S-5

Mast type	Maximum Fork Height	Fully Lowered Height	Fully Extended Height	Free Lift	Rated Load Capacities		
			With Load Backrest	With Load Backrest	D/G70S-5		
					Tilt Angle		Load Capacities
					Double Pneumatic		Double Pneumatic
					FWD	BWD	LC 600mm
	mm	mm	mm	mm	deg	deg	kg
STD	3,000	2,495	4,275	205	15	10	7,000
	3,500	2,745	4,775	205	15	10	7,000
	3,700	2,845	4,975	205	15	10	7,000
	4,000	2,995	5,275	205	15	10	7,000
	4,500	3,345	5,775	205	15	10	7,000
	5,000	3,595	6,275	205	15	10	7,000
	5,500	3,845	6,775	205	15	10	7,000
	6,000	4,095	7,275	205	15	10	6,900
	3,000	2,495	4,275	205	15	10	7,000
	3,500	2,745	4,775	205	15	10	7,000
	3,700	2,845	4,975	205	15	10	7,000
	4,000	2,995	5,275	205	15	10	7,000
	4,500	3,345	5,775	205	15	10	7,000
	5,000	3,595	6,275	205	15	10	7,000
	5,500	3,845	6,775	205	15	10	7,000
	6,000	4,095	7,275	205	15	10	6,900
FFT	4,550	2,540	5,570	1,580	15	10	7,000
	5,000	2,690	6,020	1,730	15	10	7,000
	5,600	2,890	6,620	1,930	15	10	6,725
	6,050	3,040	7,070	2,080	15	10	6,500

D80S-5

Mast type	Maximum Fork Height	Fully Lowered Height	Fully Extended Height	Free Lift	Rated Load Capacities		
			With Load Backrest	With Load Backrest	D80S-5		
					Tilt Angle		Load Capacities
					Double Pneumatic		Double Pneumatic
					FWD	BWD	LC 600mm
	mm	mm	mm	mm	deg	deg	kg
STD	3,100	2,835	4,375	215	15	10	8,000
	3,300	2,935	4,575	215	15	10	8,000
	3,600	3,085	4,875	215	15	10	8,000
	4,100	3,435	5,375	215	15	10	8,000
	4,600	3,685	5,875	215	15	10	8,000
	5,100	3,935	6,375	215	15	10	8,000
	5,600	4,185	6,875	215	15	10	8,000
FFT	4,350	2,630	5,625	1,420	15	10	8,000
	4,800	2,780	6,075	1,570	15	10	8,000
	5,400	2,980	6,675	1,770	15	10	8,000
	5,850	3,130	7,125	1,920	15	10	7,900

D90S-5

Mast type	Maximum Fork Height	Fully Lowered Height	Fully Extended Height	Free Lift	Rated Load Capacities		
			With Load Backrest	With Load Backrest	D90S-5		
					Tilt Angle		Load Capacities
					Double Pneumatic		Double Pneumatic
					FWD	BWD	LC 600mm
	mm	mm	mm	mm	deg	deg	kg
STD	3,100	2,835	4,375	215	15	10	9,000
	3,300	2,935	4,575	215	15	10	9,000
	3,600	3,085	4,875	215	15	10	9,000
	4,100	3,435	5,375	215	15	10	9,000
	4,600	3,685	5,875	215	15	10	9,000
	5,100	3,935	6,375	215	15	10	9,000
	5,600	4,185	6,875	215	15	10	9,000
FFT	4,350	2,630	5,625	1,420	15	10	9,000
	4,800	2,780	6,075	1,570	15	10	9,000
	5,400	2,980	6,675	1,770	15	10	9,000
	5,850	3,130	7,125	1,920	15	10	8,850



ISO 9001

ISO 14001

PRO5 SERIES



G50S / G60S / G70S-5
5,000kg 6,000kg 7,000kg
Pneumatic Tire

D50S / D60S / D70S-5 & D80S / D90S-5
5,000kg 6,000kg 7,000kg 8,000kg 9,000kg
Pneumatic Tire

PSC0703B1 (May.2007)



Doosan Infracore
Forklifts