



Doosan Infracore
Forklifts

Electric Powered Forklifts

Capacity Range 1,600 - 2,000kg 4 Wheel

B16X - 5
B18X - 5
B20X - 5

MAST SPECIFICATIONS AND RATED CAPACITIES

Truck Model	Mast Type	Maximum Fork Height mm	Fully Lowered Height mm	Fully Extended Height		Free Lift		Solid Soft Tire	
				With Load Backrest mm	W/O Load Backrest mm	With Load Backrest mm	W/O Load Backrest mm	Tilt Angle	Load Capacities
								FWD/BWD deg	LC500mm kg
B16X	STD	3000	2000	4045	3600	130	130	5/7	1600
	STD	3300	2150	4345	3900	130	130	5/7	1600
	STD	3500	2250	4545	4100	130	130	5/7	1600
	STD	3700	2350	4745	4300	130	130	5/7	1600
	STD	4000	2550	5045	4600	130	130	5/7	1600
	STD	4500	2800	5545	5100	130	130	5/7	1600
	FF	2700	1850	3745	3325	845	1265	5/5	1600
	FF	3000	2000	4045	3625	995	1415	5/5	1600
	FF	3300	2150	4345	3925	1145	1565	5/5	1600
	FFT	4000	1880	5050	4630	875	1295	5/5	1600
	FFT	4500	2045	5545	5125	1040	1460	5/5	1550
	FFT	4750	2130	5795	5375	1125	1545	5/5	1500
	FFT	5000	2245	6045	5625	1240	1660	5/5	1450
	FFT	5500	2480	6550	6130	1475	1895	5/5	1350
FFT	6000	2645	7045	6625	1640	2060	5/5	1250	
B18X	STD	3000	2000	4045	3600	130	130	5/7	1800
	STD	3300	2150	4345	3900	130	130	5/7	1800
	STD	3500	2250	4545	4100	130	130	5/7	1800
	STD	3700	2350	4745	4300	130	130	5/7	1800
	STD	4000	2550	5045	4600	130	130	5/7	1800
	STD	4500	2800	5545	5100	130	130	5/7	1700
	FF	2700	1850	3745	3325	845	1265	5/5	1800
	FF	3000	2000	4045	3625	995	1415	5/5	1800
	FF	3300	2150	4345	3925	1145	1565	5/5	1800
	FFT	4000	1880	5050	4630	875	1295	5/5	1800
	FFT	4500	2045	5545	5125	1040	1460	5/5	1750
	FFT	4750	2130	5795	5375	1125	1545	5/5	1600
	FFT	5000	2245	6045	5625	1240	1660	5/5	1550
	FFT	5500	2480	6550	6130	1475	1895	5/5	1475
FFT	6000	2645	7045	6625	1640	2060	5/5	1350	
B20X	STD	3000	2000	4050	3605	135	135	5/7	2000
	STD	3300	2150	4350	3905	135	135	5/7	2000
	STD	3500	2250	4550	4105	135	135	5/7	2000
	STD	3700	2350	4750	4305	135	135	5/7	2000
	STD	4000	2550	5050	4605	135	135	5/7	2000
	STD	4500	2800	5550	5105	135	135	5/7	1900
	FF	2700	1850	3750	3330	845	1265	5/5	2000
	FF	3000	2000	4050	3630	995	1415	5/5	2000
	FF	3300	2150	4350	3930	1145	1565	5/5	2000
	FFT	4000	1880	5055	4635	875	1295	5/5	1900
	FFT	4500	2045	5550	5130	1040	1460	5/5	1900
	FFT	4750	2130	5800	5380	1125	1545	5/5	1800
	FFT	5000	2245	6050	5630	1240	1660	5/5	1725
	FFT	5500	2480	6555	6135	1475	1895	5/5	1650
FFT	6000	2645	7050	6630	1640	2060	5/5	1500	

Note : These load capacities are based on the standard chassis without side shifter.

Standard equipment

- 48 Volt electric chassis with AC system
- Battery connector
- Tires
- 3-section valve with 2-levers
- Seat
- 3300mm STD 2-stage mast
- Tilt cylinder (5 deg.fwd / 7 deg.back)
- Carriage
- Load backrest
- 900mm fork
- Without battery & charger

A standard chassis includes

- 48 Volt electrical system
- Oil-cooled Disc Brake
- Power steering
- AC(Alternative Current) control panel
- Tilt steering wheel
- 2 Front floodlights
- DC/DC converter

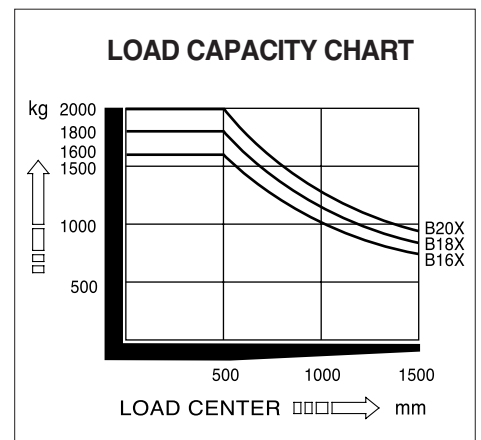

Specification values quoted in this catalog have been rounded.
Products and specifications are subject to improvement and change without notice.
Performance may vary due to operating conditions.
The performance shown represents nominal values obtained under typical operating conditions.

SPECIFICATIONS (48V AC TRUCK)

CHARACTERISTICS	2	Model			B16X	B18X	B20X	
	3	Load Capacity	at rated load center	kg	1600	1800	2000	
	4	Load Center		mm	500	500	500	
	5	Power Type			Electric	Electric	Electric	
	6	Operator Type			Driver Seated	Driver Seated	Driver Seated	
	7	Tire Type	E : Solid Soft, C : Cushion		E	E	E	
	8	Wheels (x=Driven)			2x / 2	2x / 2	2x / 2	
	DIMENSIONS	9	Max. Fork Height	with STD 2-stage mast	mm	3300	3300	3300
10		Free Lift		mm	130	130	135	
12		Fork Carriage	ISO Class					
13		Forks	Thickness x Width x Length	mm	35 x 100 x 900	35 x 100 x 900	40 x 100 x 900	
			Fork Spacing(Min / Max)	mm	240 / 905	240 / 905	240 / 905	
14		Tilt of Mast	Forward / Backward	deg	5 / 7	5 / 7	5 / 7	
15		Overall Dimensions	Length to Fork Face	mm	2093	2093	2098	
16			Overall Width	mm	1090	1090	1119	
17			Mast Lowered Height	mm	2150	2150	2150	
18			Mast Extended Height	mm	4345	4345	4350	
19			Overhead Guard Height	mm	1985	1985	1985	
20	Seat Height	mm	919	919	919			
21	Turning Radius	Minimum outside	mm	1955	1955	1955		
22	Load Moment Center		mm	376	376	381		
23	Right Angle Stacking Aisle Width With Pallets 1200 x 800 / 1000 x 1200[L x W]		mm	3731 / 3531	3731 / 3531	3736 / 3536		
PERFORMANCE	24	Speed	Travel, Loaded / Unloaded	km/h	17 / 17	17 / 17	17 / 17	
			Lifting, Loaded / Unloaded	mm/s	400 / 600	400 / 600	400 / 600	
			Lowering, Loaded / Unloaded	mm/s	500 / 450	500 / 450	500 / 450	
	28	Max, Drawbar Pull	Loaded	kg	1300	1300	1300	
	30	Max, Gradeability	at 1.6 km/h, Loaded	%	26	25	25	
WEIGHT	32	Total Weight	With minimum weight of battery	kg	3120	3290	3440	
	33	Axle Load, Loaded	Front / Rear	kg	4200 / 521	4505 / 585	4819 / 621	
	34	Axle Load, Unloaded	Front / Rear	kg	1617 / 1503	1600 / 1691	1584 / 1857	
CHASSIS	35	Tires	Number of wheels (Front/Rear)		2 / 2	2 / 2	2 / 2	
	36		Size, Front		18 x 7-8	200 x 50-10	200 x 50-10	
	37	Size, Rear		16 x 6-8	16 x 6-8	16 x 6-8		
	38	Wheel Base	Distance	mm	1410	1410	1410	
	39	Tread Width	Front	mm	902	912	912	
			Rear	mm	890	890	890	
	40	Ground Clearance	Loaded	at lowest	mm	86	86	86
				at center of wheelbase	mm	100	100	100
42	Brakes	Service			Hydraulic	Hydraulic	Hydraulic	
		Parking			Mechanical	Mechanical	Mechanical	
POWER TRAIN	45	Battery	Type		Lead-acid	Lead-acid	Lead-acid	
			Voltage / Capacity(Max)	V/AH	48 / 770	48 / 770	48 / 770	
			Minimum Weight	kg	1050	1050	1050	
	47	Electric Motors	Drive Motor - 1Hour Rating	kW	5.0 x 2	5.0 x 2	5.0 x 2	
			Hydraulic Motor - 20% Duty	kW	12.0	12.0	12.0	
	54	Control Type		type	MOSET Inverter	MOSET Inverter	MOSET Inverter	
	55	Transfer	Brake Type	type	ODB	ODB	ODB	
57	Relief Pressure	Lift	kpa	19800	19800	21550		
		Attachment	kpa	14000	14000	14000		

Dimensional drawings

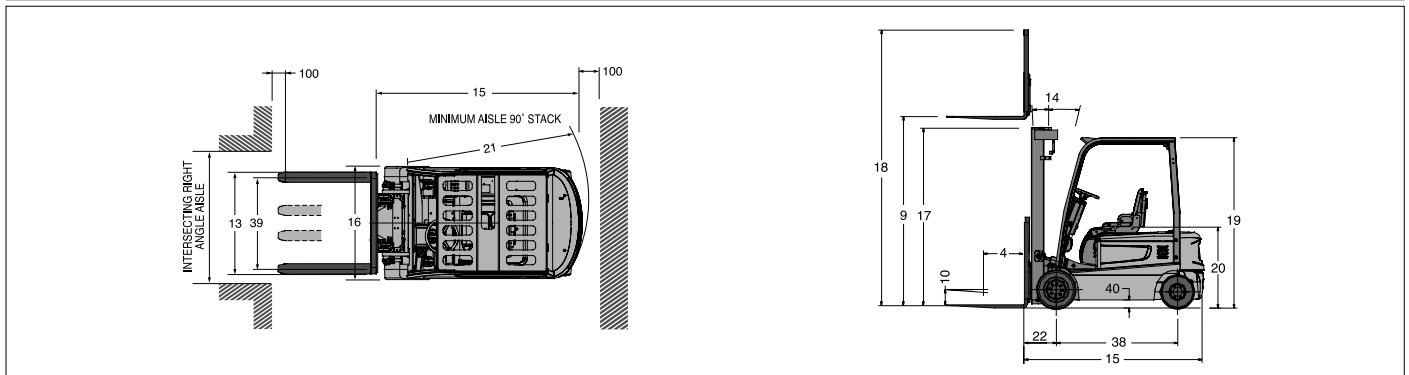

Doosan Infracore
Forklifts